

# Zbarvení a označení Camouflage and markings

Stoewer Kfz.1, 21. Pz.Division, DAK, Tripolis 1943

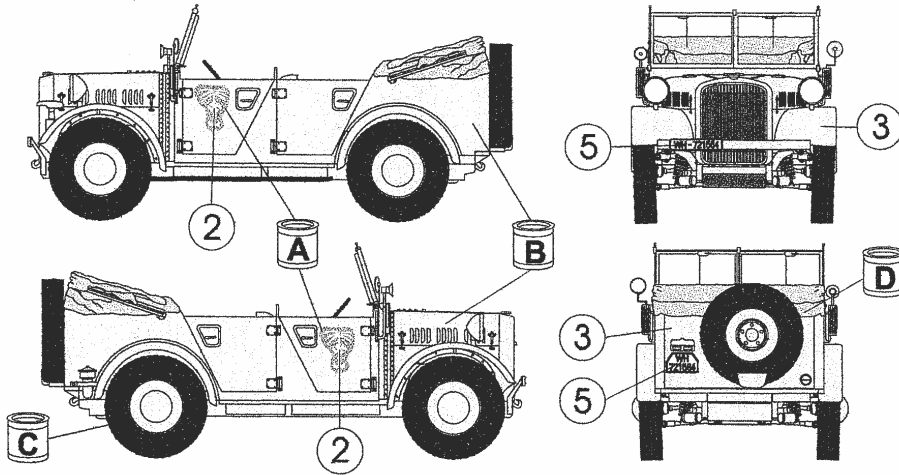

Stoewer Kfz.1, 502nd SS schwere Pz.Abteilung, Germany, autumn 1944

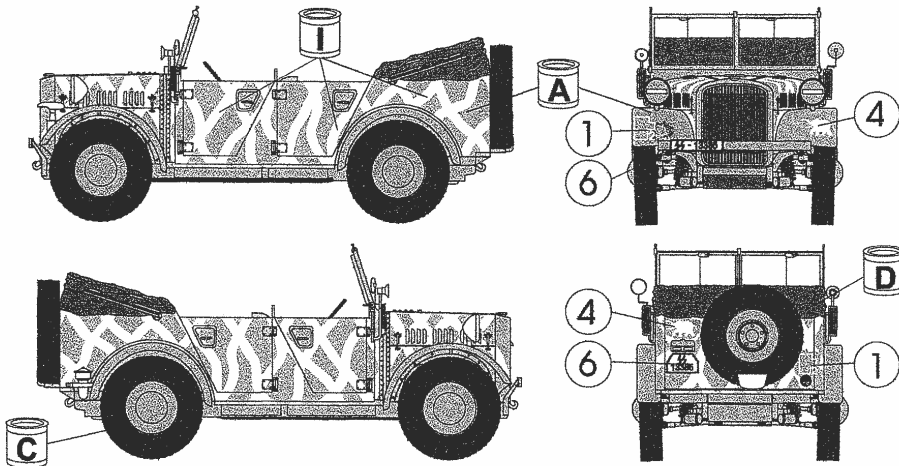

Při stavbě postupujte podle instrukčáčního obrázku

Follow the instruction drawing the assembly.

**Upozornění:** Během opracování může vznikat prach, který může dráždit dýchací cesty. Použijte ochranu očí při odštrihování kovových dílů.

**Notice:** Machining can produce dust which can be irritating to the respiratory tract. Metal parts should be cut off using protection eyesight.

Kupujte přímo na  
[www.plusmodel.cz](http://www.plusmodel.cz)

Plus Model s.r.o.  
Jižní 56, 370 10 České Budějovice  
Czech Republic  
<http://www.plusmodel.cz>  
e-mail: [plusmodel@plusmodel.cz](mailto:plusmodel@plusmodel.cz)

Buy directly from  
[www.plusmodel.cz](http://www.plusmodel.cz)

[www.plusmodel.cz](http://www.plusmodel.cz)

208

plusmodel

Scale  
1/35

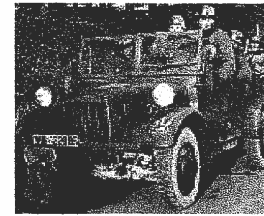

# STÖEWER Kfz.1

### Historie

Univerzální lehký terénní automobil, vyráběný firmou Stoewer v letech 1938 - 1943. Na výrobu se v letech 1937 - 1940 podílely také firmy BMW a Hanomag. Všechny vozy se v drobnostech lišily (firma BMW například používala šestiválcový motor).

Kromě starších Stoewer R180 Special a typu 40 z let 1940-43 měla všechna vozidla na přání řízení všech čtyř kol. Typy karoserií zahrnovaly Kfz.1 (čtyřmístná), Kfz.2 (spojovací), Kfz.240 (údržba a opravy) a Kfz.3 (lehké průzkumné vozidlo). Všechny typy byly používány na všech frontách II. světové války.

### Technická data:

Motor - čtyřválcový kapalinou chlazený Stover AW2 OHV objem - 1997 cm<sup>3</sup>  
Výkon - 37 kW (50k)  
Spojka - suchá kotoučová  
Převodovka - 5 stupňů vpřed, 1 vzad, přídavná jednostupňová převodovka s mezinápravovým diferenciálem

Brzdy - mechanické  
Rozvor - 2400 mm  
Délka - 3900 mm  
Šířka - 1690 mm  
Výška - 1900 mm  
Hmotnost - 1780 kg

### History

Light Universal Off-road car was built by Stoewer company in 1933 - 1943. There was produced also by BMW a Hanomag companies. There were some differences between cars (e.g. cars from BMW company had six cylinder engine).

Except Stoewer R180 Special and type 40, all vehicles had all wheels controllable. There were used four variants of vehicle body: Kfz.1 (four man), Kfz.2 (liaison), Kfz.240 (repair) and Kfz.3 (light scout car). All variants were used in all theatres of WW II. There were built about 13 000 vehicles, few of them survived.

### Technical specifications:

Engine - Four cylinder Stover AW2 OHV, 1997 cm<sup>3</sup>, 37 kW (50 HP)  
Gear box - Five forward, one reverse plus one auxiliary box  
Clutch - Disc, dry  
Brakes - Mechanical  
Fuel capacity - 60 L gasoline  
Wheel base - 2400 mm  
Length - 3900 mm  
Width - 1690 mm  
Height - 1900 mm  
Weight - 1780 kg

## Kusovník a značení dílů - Numbering of parts

### Resinové díly-Resin parts

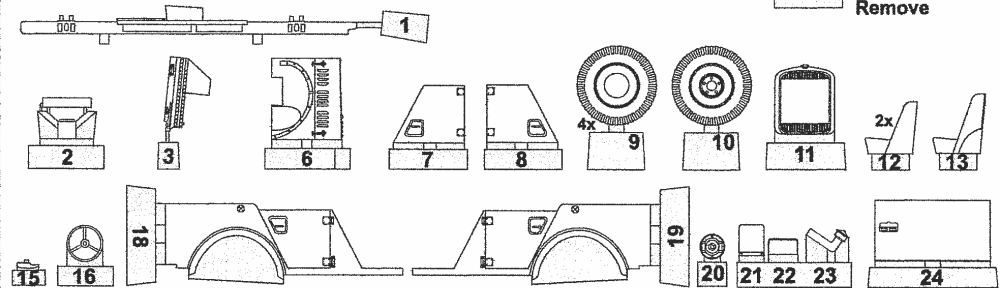

### Clear parts

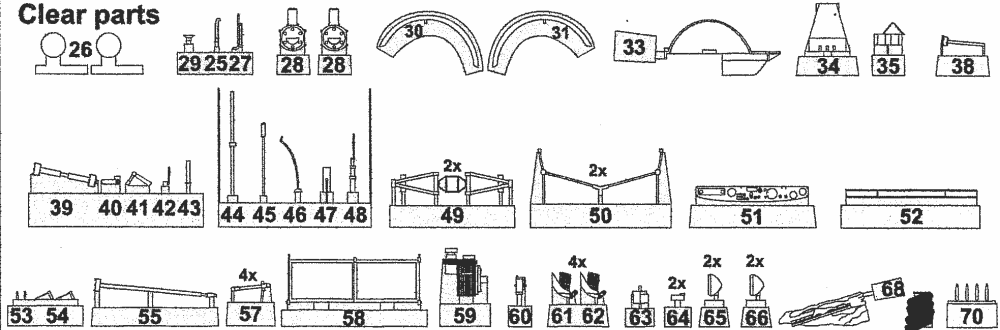

Kovové díly-Metal parts

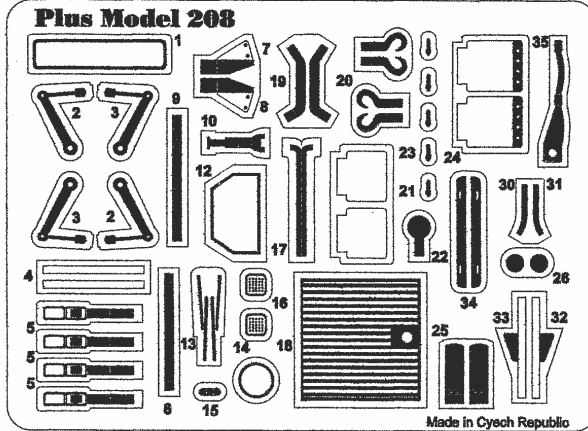

Obtisky-Decals

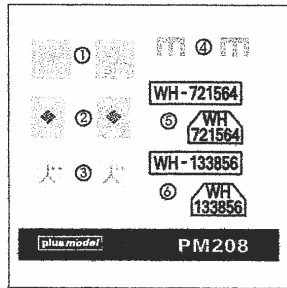

Fólie-Plastic film



Barvy - Colours



Symbols - Symbols

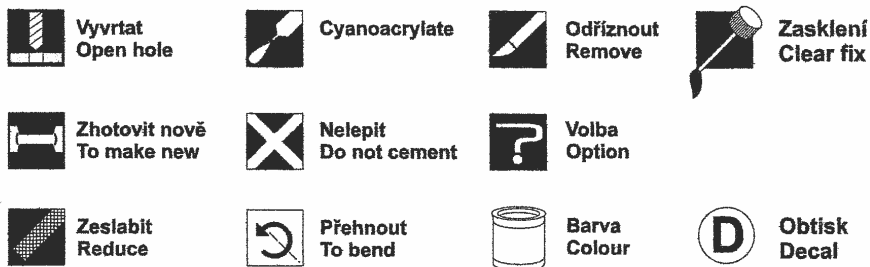

Stavební postup - Assembly instructions

22

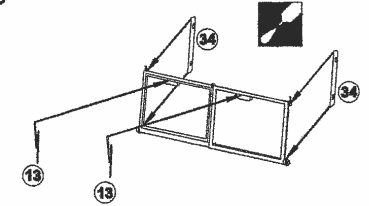
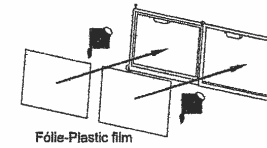
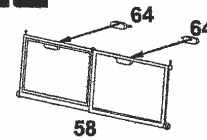

23

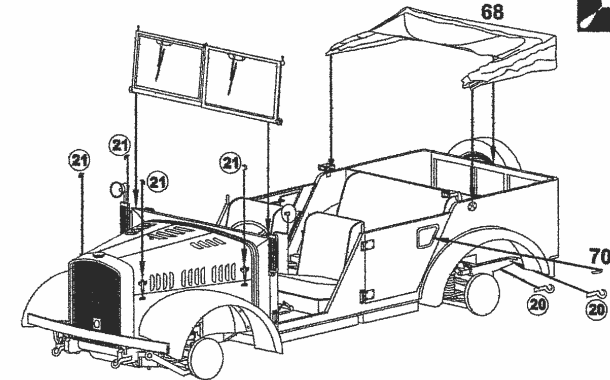

24

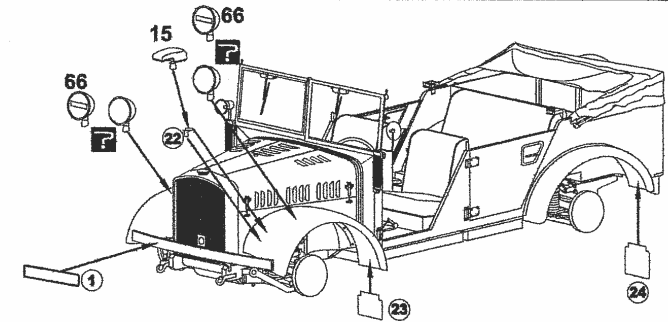
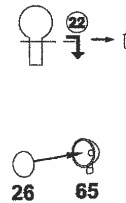

25

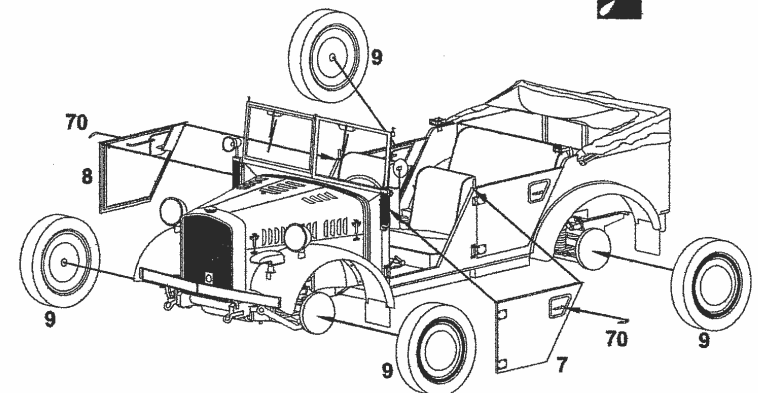

Stavební postup - Assembly instructions

19

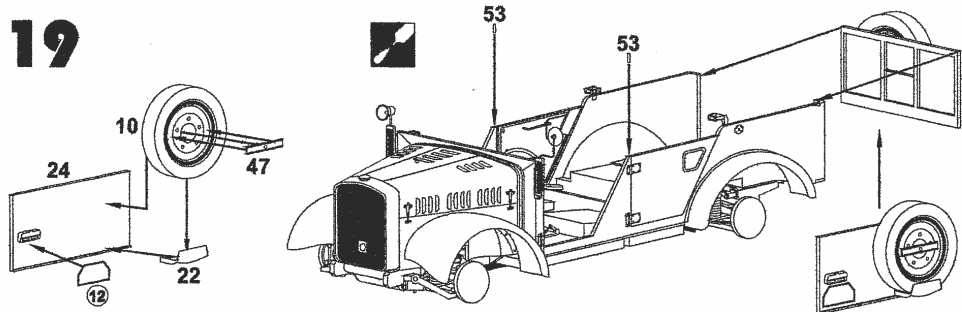

20

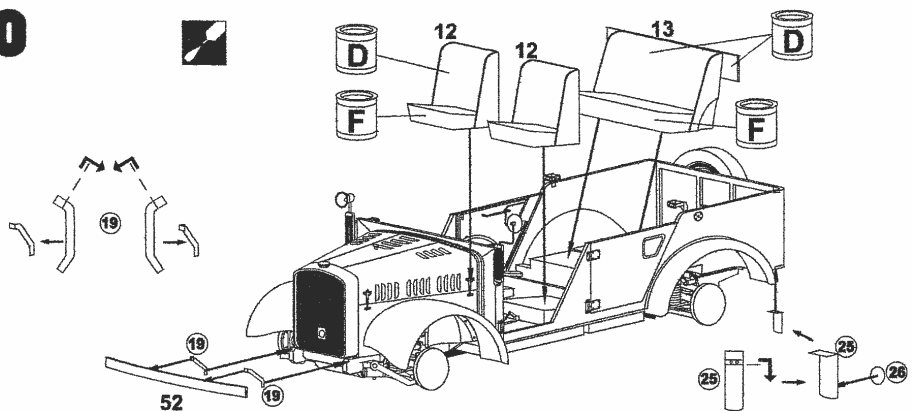

21

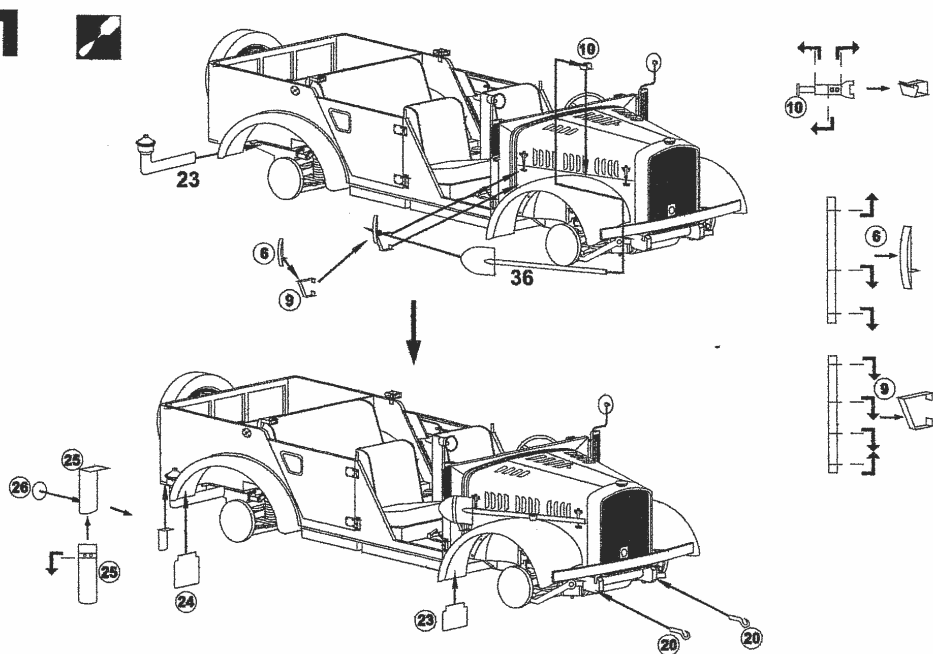

Stavební postup - Assembly instructions

1

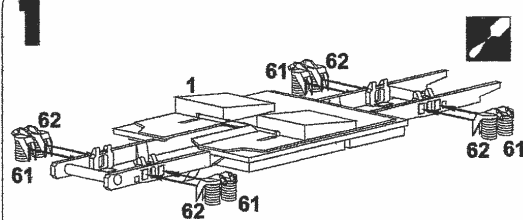

2

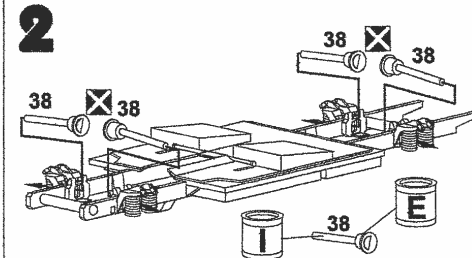

3

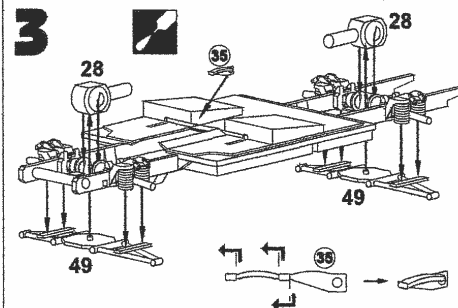

4

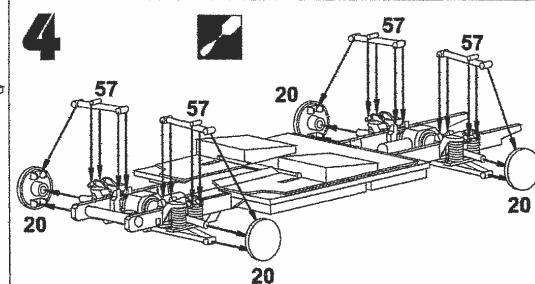

5

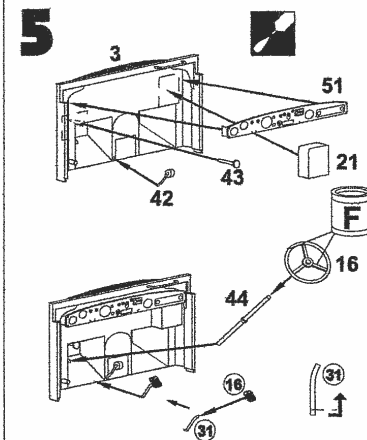

6

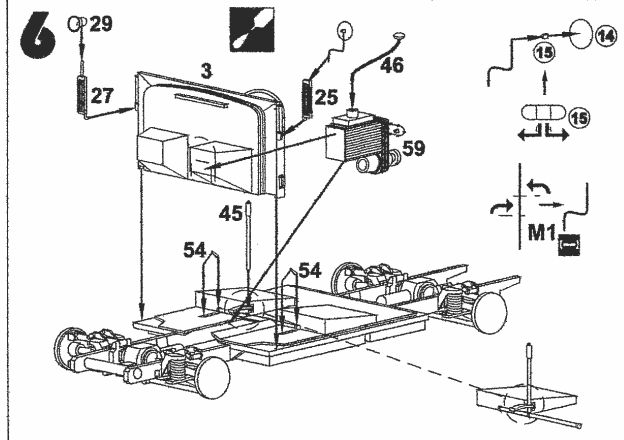

7

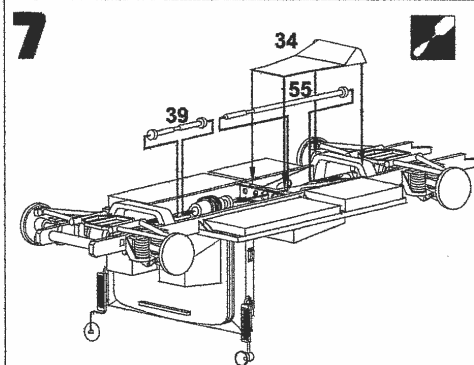

8

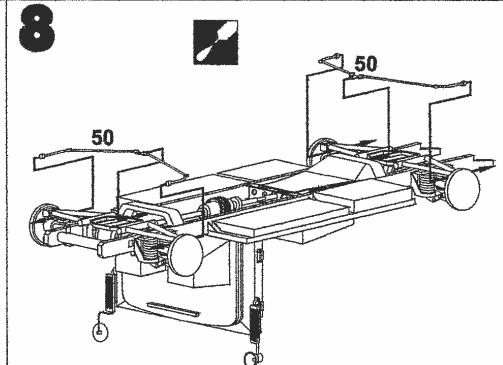

Stavební postup - Assembly instructions

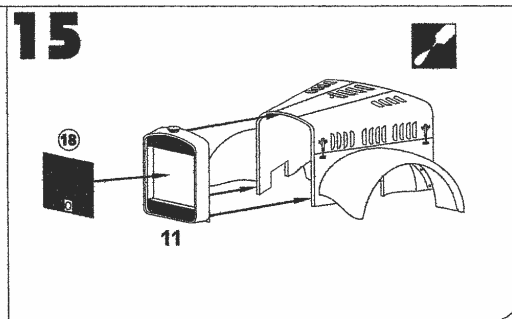
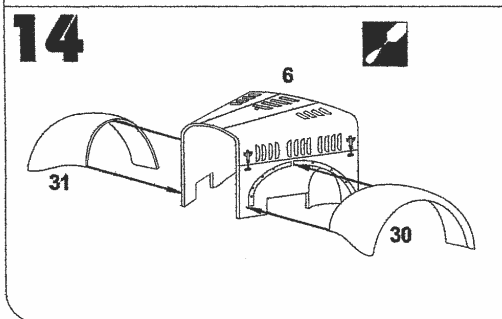
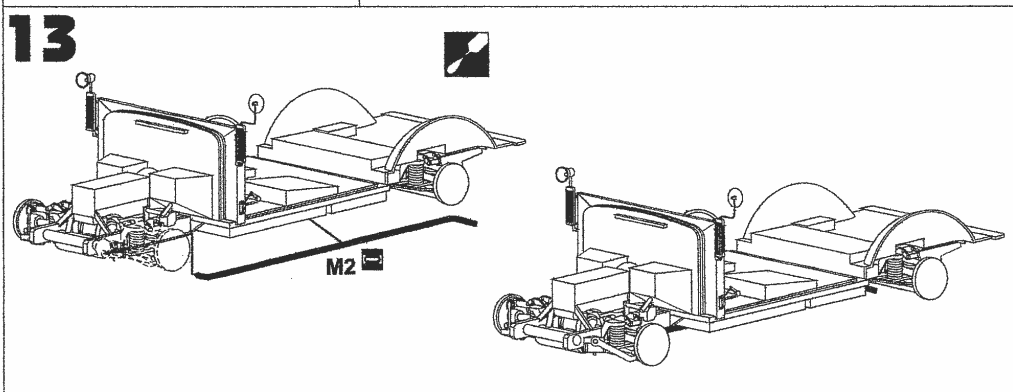
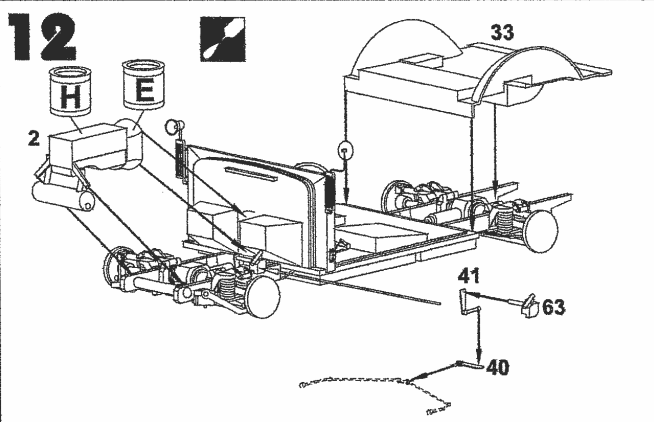
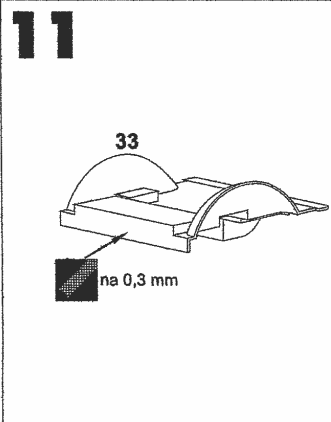
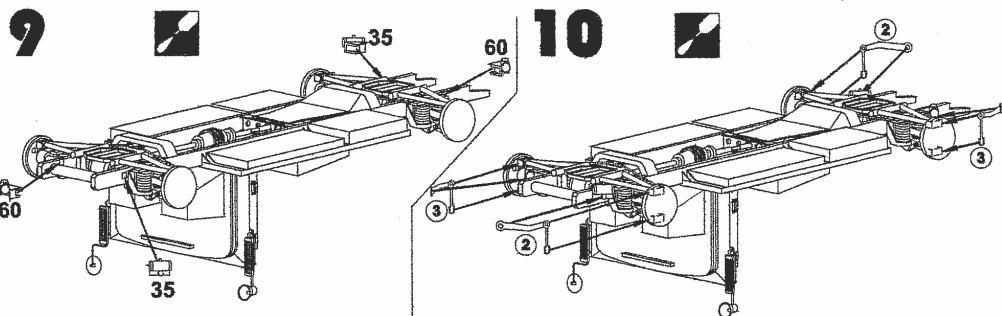

Stavební postup - Assembly instructions

